

▶ Polycom® HDX 7000™ Series

High Definition Quality for the
Standard Conference Room



Telepresence solutions for organizations that want to bring together dispersed team members for enhanced collaboration

The Polycom® HDX 7000™ Series provides flexible, affordable HD video conferencing for high-quality communication throughout mainstream workplace environments. Expanding the utility of visual communication quickly and easily, Polycom HDX 7000 Series systems are ideal for education, medical, enterprise and on-demand collaboration applications.

Enhancing Collaboration with HD Technology

Intuitive interfaces allow users to adopt and use Polycom HDX 7000 Series systems quickly, while a variety of bundle options enable the Polycom HDX 7000 Series systems to be wall-mounted, free-standing or easily wheeled to any location to accommodate visual communication in any room. With embedded multipoint and content sharing capabilities, Polycom HDX 7000 Series systems allow individuals to collaborate in HD detail on content such as diagrams, project plans, multimedia presentations and more.

Leveraging Polycom's renowned quality and designed to high-definition standards, Polycom HDX 7000 Series systems utilize features such as Polycom HD Voice™ technology to deliver patented, crystal-clear audio and Polycom StereoSurround™ audio to separate room sounds into left and right channels to deliver physical-sense spatiality to opposite-end participants.

Rich-Media Presentations Made Easy

For rich-media group presentations, Polycom HDX 7000 Series systems display dynamic content and data in HD to enhance collaboration and audience participation. With Polycom People+Content™ collaboration technology, users can share presentations and live video simultaneously, allowing conference participants to interact naturally and dynamically.

Polycom HDX 7000 Series systems are a key element of the total Polycom visual communication solution, which includes seamless integration with the Polycom RMX 1000™ or RMX 2000™ conference platforms, as well as with Polycom Converged Management Application™ 5000 for management and scheduling.

Find Out More

Learn what the Polycom HDX 7000 Series can do for your organization. Visit us at www.polycom.com or contact your Polycom representative.

Benefits

- ▶ High-definition video conferencing – Natural communications in 1280 x 720 at 30 fps (720p), with exceptional resolution even at lower data rates
- ▶ High-definition voice – Polycom Siren™ 22 and Polycom StereoSurround™ technology for superior audio performance
- ▶ High-definition content sharing – Polycom collaboration technology for sharing graphics, presentations and rich-media content with HD and non-HD systems
- ▶ Embedded multipoint – Optional four-way embedded multipoint bridge for greater flexibility and participation
- ▶ Flexible connectivity – Optional interfaces for easy access to BRI, PRI or V.35 networks

Polycom HDX 7000 Specifications

Models Available

- HDX 7001™ & 7002™ (includes Polycom EagleEye™ camera, codec, microphone array, cables and remote control)
- XL Package (includes Polycom People+Content and 2nd monitor)
- XLP Package (includes Polycom People+Content, 2nd monitor, MPPlus and 4 Mbps line rate)

Video Standards and Protocols

- H.264, H.263++, H.261
- H.239 / Polycom People+Content
- H.263 & H.264 Video Error Concealment

People Video Resolution

- 720p, up to 30fps at 1 Mbps – 2 Mbps*
- 4SIF (704 x 480)/4CIF (704 x 576) at 256 Kbps-2 Mbps
- SIF (352 x 240), CIF (352 x 288)
- QSIF (176 x 120), QCIF (176 x 144)

Content Video Resolution

- Up to 720p*
- Input: SXGA (1280x1024), XGA (1024 x 768),
- SVGA (800 x 600), VGA (640 x 480)
- Output: XGA (1024x768), SVGA (800x600)

Camera

- Polycom EagleEye Camera
 - 1280 x 720p CCD imager
 - 12X optical zoom
 - 72deg FOV at min zoom
 - +/- 100 deg pan range
 - +20/-30 deg tilt range
 - Output formats: SMPTE 296M 1280 x 720p, 50/60 FPS

Audio Standards and Protocols

- Polycom StereoSurround
- 22 kHz bandwidth with Polycom Siren 22
- 14 kHz bandwidth with Polycom Siren 14, G.722.1
- Annex C
- 7 kHz bandwidth with G.722, G.722.1
- 3.4 kHz bandwidth with G.711, G.728, G.729A
- Automatic Gain Control
- Automatic Noise Suppression
- Keyboard Noise Reduction
- Live Music Mode
- Instant Adaptation Echo Cancellation
- Audio Error Concealment

Other ITU-Supported Standards

- H.221 communications
- H.224/H.281 far-end camera control
- H.323 Annex Q far-end camera control
- H.225, H.245, H.241, H.331
- H.239 dual stream
- H.231 in multipoint calls

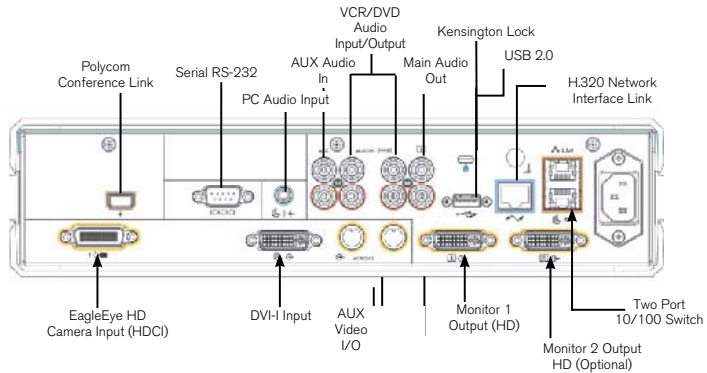

- H.243 chair control
- H.460 NAT/firewall traversal
- BONDING, Mode 1

Network

- iPriority™ for QoS
- Interfaces
 - 2-port 10/100 auto NIC switch, RJ45 connectors
- H.323 up to 4 Mbps
- Lost Packet Recovery™ (LPR™)
- Reconfigurable MTU size (IP only)
- RS232
 - Camera control
 - Data pass-through
 - Audio mixer control
- SIP up to 2 Mbps
- H.320 (Optional)
 - ISDN Quad BRI
 - ISDN PRI T1 or E1
 - Serial (RS449, V.35, RS 530) up to 2 Mbps
 - Auto SPID detection and line number configuration

User Interface

- Directory Services
 - System Management
 - Web-based
 - SNMP
 - Polycom Converged Management Application™
 - CDR
 - International languages (17)
 - RSS 2000 integration with HDX remote control
 - USB Software Update
- ## Security
- Secure Web
 - Secure Telnet
 - Security mode
 - Embedded AES FIPS 197, H.235V3 and H.233/234
 - Secure password authentication

Options

- People+Content
- MPPlus software for up to 4 sites
- 2nd Monitor

- Network Interfaces Modules
- IP 7000 speakerphone integration
- HDX Media Center options

Electrical

- Auto sensing power supply
- Typical operating voltage/power 189VA @ 115V @ 60 Hz @ .67 PF
- Typical operating voltage/power 192VA @ 230V @ 60 Hz @ .66 PF
- Typical operating voltage/power 196VA @ 230V @ 50 Hz @ .65 PF

These numbers were empirically collected under TYPICAL operating conditions. No attempt was made to force max power consumption. Voltages and currents are RMS. Power units are Volt-Amp.

Environmental Specification

- Operating Temperature: 0-40°C
- Operating Humidity: 10-80%
- Non-Operating Temperature: -40° -70° C
- Non-Operating Humidity (Non-condensing): 10-90%
- Maximum altitude: 10,000 feet

Physical Characteristics

- HDX 7000 Base Box with removable stand
 - 13.87" (H) x 5.08" (W) x 11" (D)

Warranty

- One-year return to factory parts and labor
- 90-day software warranty

Technical Documentation

- Documentation for setting up, maintaining, and using the system, available at www.polycom.com/videodocumentation
- Documentation for available 720p software for HDX 7001 at http://www.polycom.com/usa/en/support/video/hdx_series/hdx7000.html

**Standard on HDX 7002; software enhancement available for Polycom HDX 7001*

©2008 Polycom, Inc. All rights reserved. Polycom, ReadIManager and the Polycom logo design are registered trademarks and HDX 7000, HDX 7001, HDX 7002, HD Voice, StereoSurround, People+Content, Siren, RMX 2000, Polycom Video Media Center, VMC 1000, EagleEye, Lost Packet Recovery (LPR), PathNavigator, Global Management System are trademarks of Polycom, Inc. in the U.S. and various countries. All other trademarks are the property of their respective owners. Information in this document is subject to change without notice.