



EV Innovative Design

EVID FM4.2 Dual 4" Two-Way Flush-Mounted Loudspeaker System



Key Features:

- 4" two-way system with polypropylene diaphragm for reliable long-term operation.
- 4" passive radiator coupled to the woofer dramatically extends and smoothes the low frequency response.
- Extremely compact depth fits into tight spaces including walls and tight ceiling spaces.
- Titanium coated tweeter gives even uniform high frequency coverage
- Full bandwidth overload protection
- Front baffle wattage tap adjustment allows for easy level matching after installation.
- Easy 4 pin phoenix style terminals for quick installation.
- Integrated low loss matching transformer allows for either 70v/100v or 8 ohm operation.

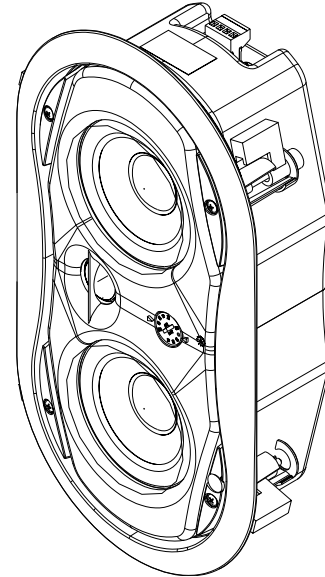

General Description:

The Electro-Voice® EVID FM4.2 flush-mounted loudspeaker system is a complete two-way in-wall loudspeaker package. The package consists of a bezel assembly, grille, rear enclosure, 4" two-way loudspeaker coupled with a 4" passive radiator and an internal line-matching transformer. The loudspeaker features 4" low-frequency cone and high-temperature voice-coil assembly along with a 4" long excursion passive radiator and titanium coated dome tweeter. The EVID FM4.2 loudspeaker utilizes a crossover network, centered at 3,600 Hz, that provides 16-dB-per-octave tweeter protection outside of its operating range. In addition the EVID FM4.2 features a comprehensive protection circuit to shield the woofer and tweeter drivers from excessive power levels.

The EVID FM4.2 utilizes a transformer that offers a selection of 1.75, 3.75, 7.5, 15 or 30 watts delivered to the loudspeaker system using either 70-V or 100-V lines. The wattage is selected via a convenient switch on the front baffle. The unit can also be operated as an 8-ohm speaker via the same front panel selector switch.

The perforated grille is finished in semi-gloss white powder-coated enamel. The baffle and bezel is constructed from heat resistant ABS. The rear enclosure is constructed from zinc-plated, steel. The rear enclosure provides an optimum internal volume, ensuring extended low-frequency performance. It is constructed from heavy-gauge, rugged steel. The steel rear enclosure was optimized using FEA to virtually eliminate panel resonance. The entire enclosure is less than 4" deep providing an easy installation into nearly any tight wall or ceiling space. A rear cover, with provisions for a junction box fitting, provides access to a 4-pin terminal block that allows direct connection to the speaker and provides pass through to additional speakers. FM4.2 loudspeakers provide wide dispersion, high-efficiency, high-maximum output, ease of installation, and wide-range reproduction of music or voice.

Technical Specifications:

Freq. Response (-3 dB):	70 Hz - 20 kHz
Freq. Range (-10 dB):	52 Hz - 20 kHz
Axial Sensitivity:	87 dB (SPL 1W/1m)
Impedance:	8 ohms nominal (transformer bypass)
Crossover Frequency:	3.6 kHz
Rec. Highpass Frequency:	70 Hz
Power Handling ¹ :	100W Cont. Prog. / 200W Peak
HF Transducer:	1 in. (25.4 mm)
LF Transducer:	4 in. (101.6 mm)
Passive Radiator:	4 in. (101.6 mm)
Transformer Taps:	70V: 1.75, 3.75, 7.5, 15, or 30W 100V: 3.75, 7.5, 15, or 30W Bypass: 8 ohms nominal
Connectors:	4 pin phoenix style terminals
Enclosure Material:	Baffle: UL 94V-O rated ABS Backcan: Zinc plated steel
Grille:	Perforated powdercoated steel with safety tether
Mounting System:	Integrated toggle anchors
Support Hardware:	Cutout template, Paint Shield
Dimensions:	349.9mm x 188.3mm x 96.5mm (13.77" x 7.42" x 3.80")
Net Weight (Each):	2.9 kg (6.5 lb)
Shipping Weight (Pair):	6.8 kg (15.0 lb)

All Specifications based on Half-Space Environment as flush-mounted.

¹ Continuous Program Rating: 3 dB greater than continuous pink noise rating (IEC-shaped pink noise with 6 dB crest factor)



Architects' and Engineers' Specifications:

The EVID FM4.2 loudspeaker system shall be comprised of a baffle/bezel assembly, front grille, rear enclosure, transformer, 4" passive radiator, and 4" loudspeaker. The loudspeaker will feature an 4" low-frequency cone and a high-temperature voice-coil assembly, coupled with a 4-inch passive radiator. A 1" wide dispersion titanium coated dome tweeter extends the response to 20 kHz. Frequency response, uniform from 85 Hz to 18 kHz. Pressure sensitivity, 87 dB SPL at 1 meter (85 dB at 4 feet) on axis with one watt of band-limited pink noise from 500 Hz to 3 kHz (ref. 20µPa). Minimum impedance, 8.2 ohms. The loudspeaker shall be 349.9 mm (13.77 in.) by 188.3 mm (7.42 in.) and 96.5 mm (3.80 in.) deep. Weight shall be 2.9 kg (6.5 lb) each. The flush-mounted loudspeaker package shall be the Electro-Voice® model FM4.2.

Block Diagram:

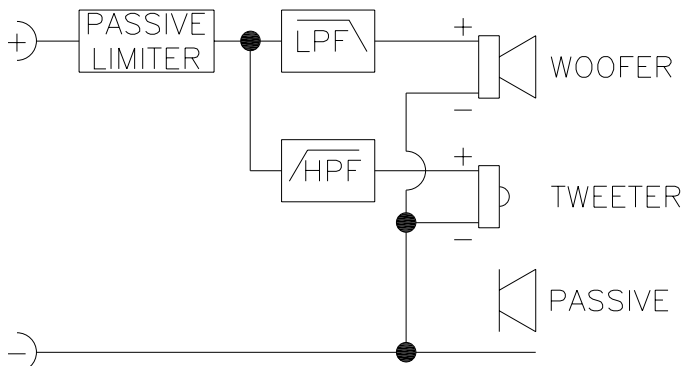

Dimension Drawings:

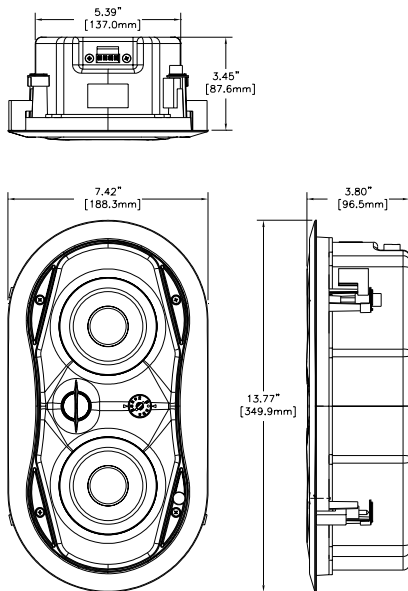

Frequency Response:

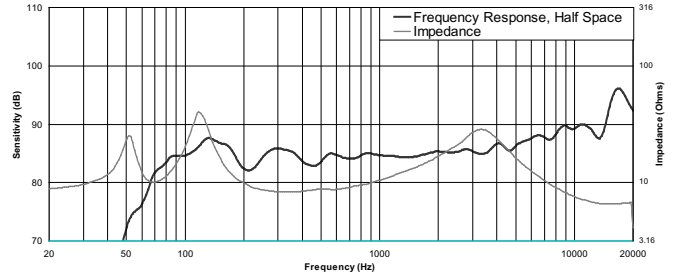

Beamwidth:

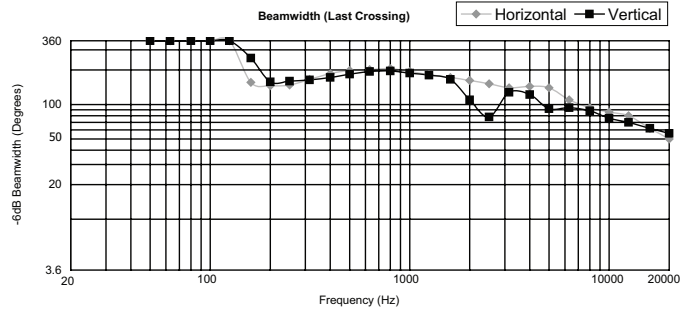

Directivity:

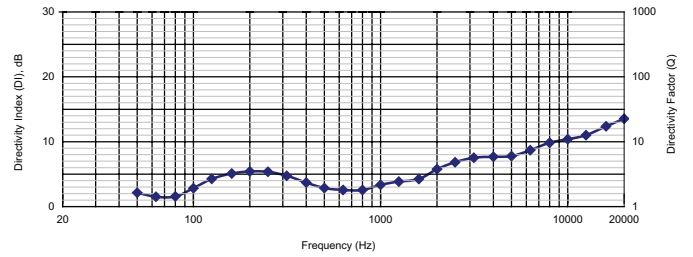

Performance Match:

- D170406 PA2400T, 2x400 70v Power Amplifier
- D170407 PA2250T, 2x250 70v Power Amplifier
- D170408 PA2450L, 2x450 Power Amplifier
- D170409 PA4150L, 4x150 Power Amplifier

EVID FM4.2 Part Numbers:

- PRD000120-000

Electro-Voice®

12000 Portland Avenue South, Burnsville, MN 55337
Phone: 952/884-4051, Fax: 952/884-0043

www.electrovoice.com

© Bosch Communications Systems

07/2009

Part Number LIT000234 Rev 3



Québec Montréal
Tél. : (418) 681-2470 Tél. : (514) 871-1994

www.presence.qc.ca