

Key Features:

- Line-array enhanced coverage control
- Organic, unobtrusive shape
- Strong-Arm-Mount™ for easy, flexible aiming
- Full-bandwidth overload protection
- Weather resistant - Conforms to Mil Spec 810 and IEC 529 IP 34
- Dual LF transducers for extended bass and greater power handling and output
- Ti direct-radiator HF transducer, Neodymium structure
- High sensitivity
- Magnetically shielded
- Zinc-plated grilles
- Transformer Versions

General Description:

The EVID 4.2 is a very compact full range loudspeaker ideal for indoor and outdoor applications requiring high-quality sound. Its shape and size make it nearly invisible for use in background/foreground music systems for restaurants, bars, patios, retail, and other applications

The 4.2's three-dimensional elliptic baffle symmetrically locates the 1" Ti high frequency element with a Coherent Coverage Waveguide in front of, and between the 4" low frequency drivers. This careful shaping, location, and 10° splaying of the lf units provides coverage control by the resulting line array. Lobing is controlled by physically "shadowing" the lf transducers from each other over the bandwidth they would normally exhibit interference. EVID's mounting system provides greater range of aiming angles in both horizontal and vertical planes than other types. The curved grille features designed-in weather resistance and a hidden leash for safety.

All models are available in black or white, and can easily be painted to match the décor. Transformer versions are also available for constant voltage systems.



Technical Specifications:

Frequency Response ¹ (-10 dB)	65Hz - 20kHz
Power Handling ²	200W Cont. Prog./400W Peak
Sensitivity ³	89 dB, 1W/1m
Impedance	8 ohms
Max SPL	113 dB
Horizontal Coverage ⁴	120°
Vertical Coverage ⁴	80°
Crossover Frequency	2.2 kHz
LF Transducer	2 x 4" (100 mm)
HF Transducer	1" (25 mm)
Protection	Full System
Weather Resistance	Meets Mil Spec 810 humidity, salt spray, temperature and UV, and IEC 529 IP 34 splashproof ratings
Swing x Rotation	100° x 90°
Terminals	Phoenix Connector
Enclosure Material	ABS (paintable)
"t" Version Wattage Taps	70V: 3.75 W 70V/100V: 7.5W, 15W, 30W, 8 ohm bypass
Dim (H x W x D)	12.2" x 6.9" x 8.5" (234 mm x 127 mm x 165 mm)
Net Weight (each)	8.5 lbs (3.9 kg)
Shipping Weight (pair)	19 lbs (8.6 kg)
Included Accessories	SAM™, hex key
¹ Half Space (wall mounting)	
² Continuous Program Rating: 3 dB greater than continuous pink noise rating (IEC-shaped pink noise with 6dB crest factor)	
³ Avg: Half Space (wall mounting)	
⁴ When mounted with long axis in vertical plane	

Architecture & Engineering Specs:

The loudspeaker shall be a two-way system consisting of two 4" (102mm) low-frequency transducers, 1" (25mm) high-frequency transducer with a Coherent Coverage Waveguide, and frequency-dividing network installed in a vented, line array enclosure. The network shall include a passive limiter for both the low frequency and high frequency transducers. The loudspeaker system shall meet the following performance criteria: Power handling, 200 watts of EIA RS-426A continuous pink noise (6 dB crest factor); Frequency response, 65 Hz – 20 kHz (-10 dB from rated sensitivity); Pressure sensitivity, 89 dB at one watt, 200 Hz – 10 kHz at one meter; Impedance, 8 ohms nominal, 6 ohms minimum. The high frequency transducer shall drive a waveguide to evenly cover 120° horizontally by 80° vertically. The enclosure shall be molded of acrylic butyl styrene. The enclosure shall be 12.2" (310mm) high, 6.9" (175mm) wide, 8.5" (216mm) deep. The finish shall be a paintable black or white. The grille shall be zinc plated, powder coated for corrosion resistance, and restrained with a safety leash. The loudspeaker shall be adjustable over a range of 100° horizontally and 90° vertically. The support bracket shall be low profile and integral with the enclosure. The system shall be weather resistant to MIL Spec 810 and IEC 529 IP 34 test conditions. The surface mount loudspeaker shall be the Electro-Voice® EVID model 4.2.

Block Diagram:

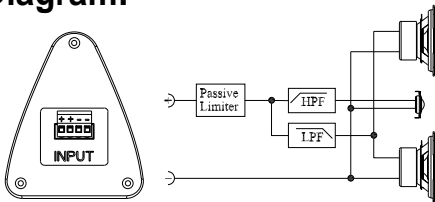

Dimension Drawings:

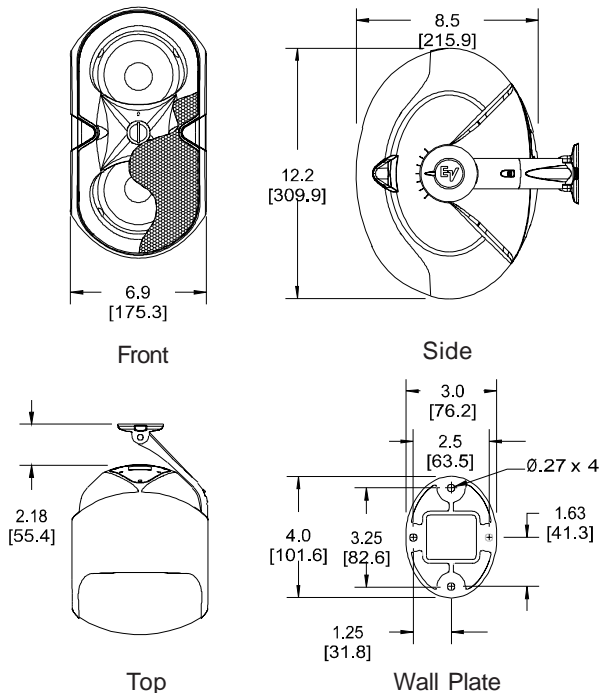

Frequency Response:

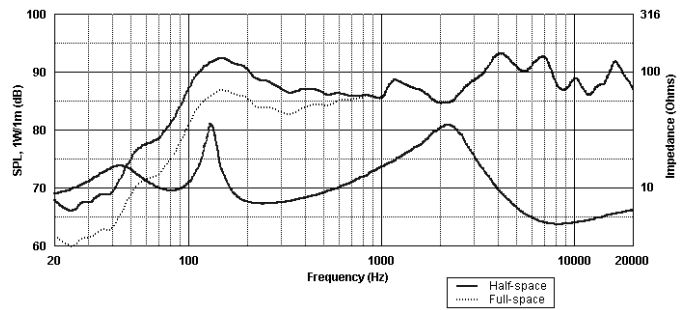

Beamwidth:

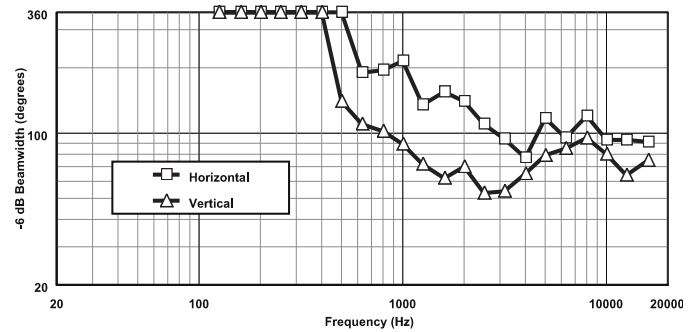

Directivity:

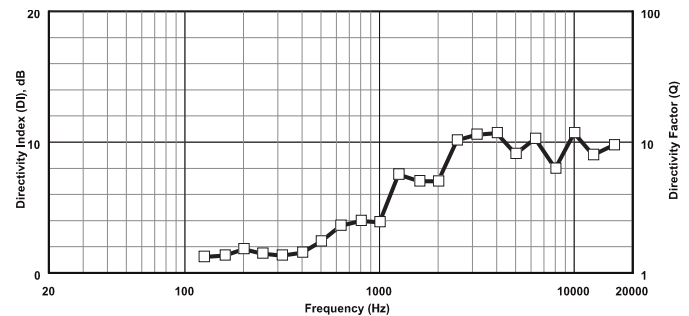

Performance Match:

- EVID 12.1 Sub

Available Accessories:

- HS-3 Horizontal Mount Desk Stand for 3.2/4.2
- VS-4 Vertical Mount Desk Stand for 4.2
- AB-ZE Array Bracket Kit for 2 or 4 ZX1i or EVID Systems, Black
- TC-4B Black Weatherized Terminal Cover for 4.2
- TC-4W White Weatherized Terminal Cover for 4.2

EVID 4.2 Part Numbers:

- 301046-001 Black
- 301046-002 White
- 301046-003 Black, Transformer
- 301046-004 White, Transformer



12000 Portland Avenue South, Burnsville, MN 55337

Phone: 952/884-4051, Fax: 952/884-0043

www.electrovoice.com

© Telex Communications, Inc. 1/2007

Part Number 38109-982 Rev F



Québec Montréal
Tél. : (418) 681-2470 Tél. : (514) 871-1994

www.presence.qc.ca